

SPIROL[®]

DISC SPRINGS

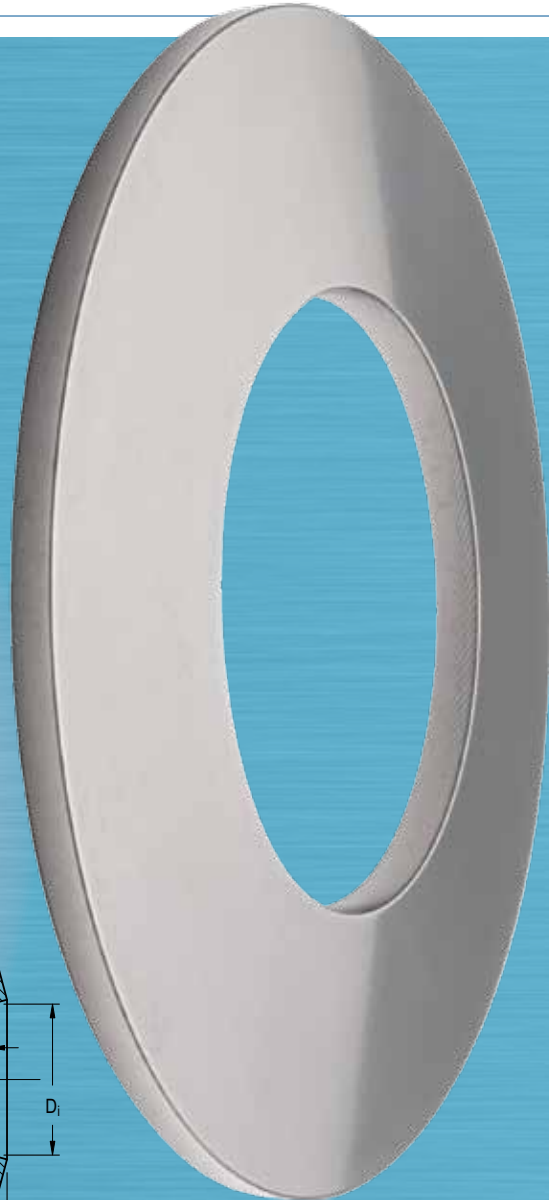

Disc Springs are conically-shaped, washer-type components designed to be axially loaded. What makes Disc Springs unique is that based on the standardized calculations of DIN 2092, the deflection for a given load is predictable and the minimum life cycle can be determined. Disc Springs can be statically loaded either continuously or intermittently, or dynamically subjected to continuous load cycling. They can be used singly or in multiples, stacked parallel, in series or in a combination thereof.

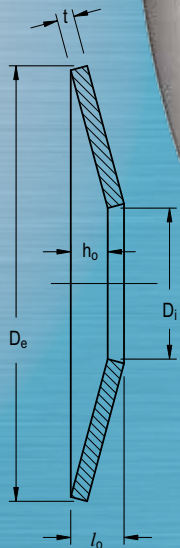
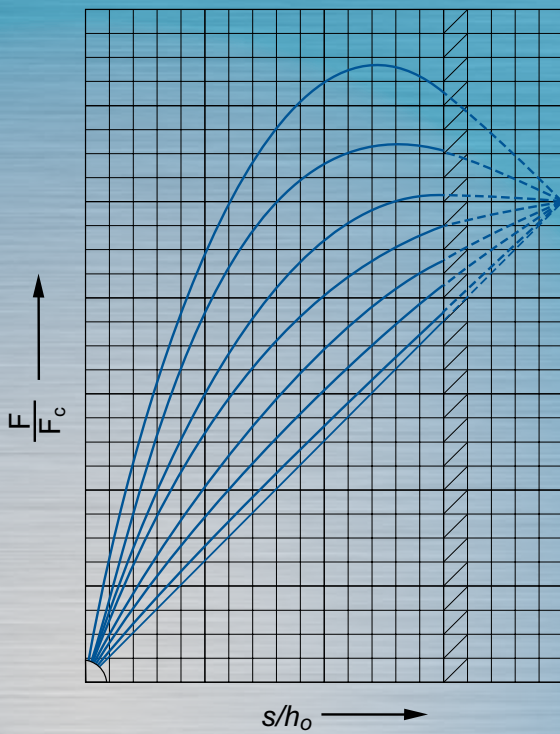

The advantages of Disc Springs compared to other types of springs include the following:

- **A wide range of load/deflection characteristics**
- **High load capacity with small deflection**
- **Space savings – high load to size ratio**
- **Consistent performance under design loads**
- **Longer fatigue life**
- **Inherent dampening especially with parallel stacking**
- **Flexibility in stack arrangement to meet your application requirements**

DIMENSIONAL DESIGNATIONS

D_e = External Diameter of Disc
 D_i = Internal Diameter of Disc
 l_o = Free Height of Disc
 t = Material Thickness of Disc
 h_o = Free Cone Height of Disc

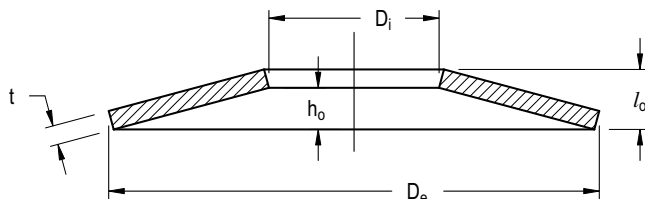

SYMBOLS AND UNITS USED IN THE APPLICATION OF DISC SPRINGS

F = Force or Load Applied	N
s = Deflection of Disc Resulting from an Applied Force	mm
σ = Stress	N/mm ²
E = Modulus of Elasticity	N/mm ²
μ = Poisson's Ratio	—



DISC SPRINGS

STANDARD PRODUCT RANGE

DIN 2093 RANGE

SPIROL offers the full range of DIN 2093 Group 1 and 2 Disc Springs in Series A, B, and C.

SPIROL STANDARD RANGE

In addition to the DIN specified sizes, **SPIROL** stocks its own standard size range in outside diameters from 8mm to 200mm in order to meet the diverse needs of its customers. **SPIROL** Standard Disc Springs meet all material, dimensional tolerance, and quality specifications as laid out in DIN 2093 but in diameter and thickness combinations that are not included in the DIN standard.

STANDARD PRODUCT DEFINITIONS

PROPERTY	GROUP 1	GROUP 2
THICKNESS	<1.25mm	1.25mm up to 6mm
MATERIAL	Code B – Carbon Steel C67S (1.1231) / UNS G10700	Code W – Alloy Steel 51CrV4 (1.8159) / UNS G61500
HARDNESS	HV 425-510 (HRC 43-50)	HRC 42-52 (HV 412-544)
FINISH	Code R – Zinc Phosphate and Oil	

Within each Group there are three Series — A, B, and C. These series are differentiated by material thicknesses and the corresponding force/deflection curves they generate ([see page 2](#)). DIN 2093 categorizes the three series by the following approximate ratios:

SERIES A	$D_e/t \approx 18$	$h_o/t \approx 0.4$
SERIES B	$D_e/t \approx 28$	$h_o/t \approx 0.75$
SERIES C	$D_e/t \approx 48$	$h_o/t \approx 1.3$

*See pages 9-13 for **SPIROL**'s standard offering.*

In addition to the standard offerings, **SPIROL** offers a line of austenitic **Stainless Steel Disc Springs**.

MATERIAL	Code D – SAE 301 Stainless Steel Full Hard (X10CrNi18-8 No 1.4310 / UNS 30100)
FINISH	Code K – Plain finish, not oiled.

*See page 14 for **SPIROL**'s standard offering.*

SPECIALS

SPIROL will work with the customer to develop special Disc Springs to meet the requirements of the application. Factors to take into consideration are forces, working parameters, environment, duty cycle, and required life. **SPIROL** can provide special dimensions, materials, finishes, and packaging to suit the application.

TO ORDER: Product / D_e x D_i x t / material code / finish code

EXAMPLE: DSC 25 x 12.2 x 0.7 BR

THEORETICAL VERSUS MEASURED DEFLECTION

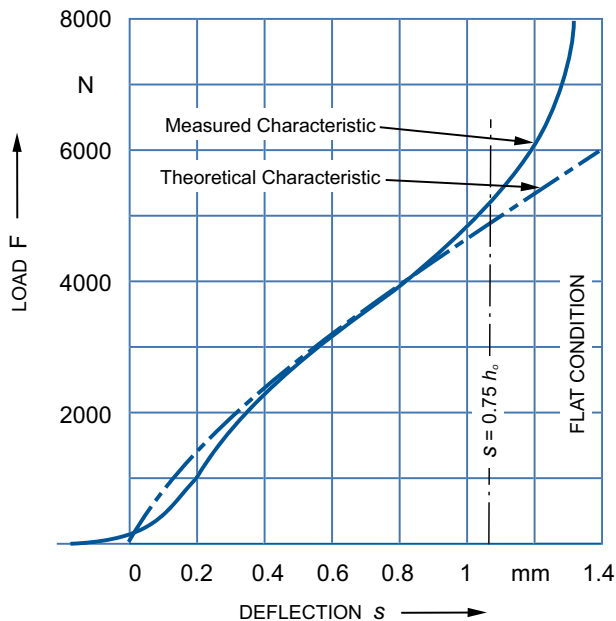

At the lower range, the actual measured curve departs slightly from the theoretical due to residual stresses.

In the mid range – the usual working range – the actual measured deflection very closely coincides with the theoretical.

As the deflection increases, the force moment arm shortens and the force required increases sharply. When the s/h_0 ratio exceeds 0.75, the deviation from the theoretical increases sharply. Accordingly, force/deflection predictability is limited to 75% of total deflection (h_0).

The graph demonstrates the characteristic of a DIN 2093 Disc Spring, Group 2, Series B 50 x 25.4 x 2.

LOAD/DEFLECTION RELATIONSHIP

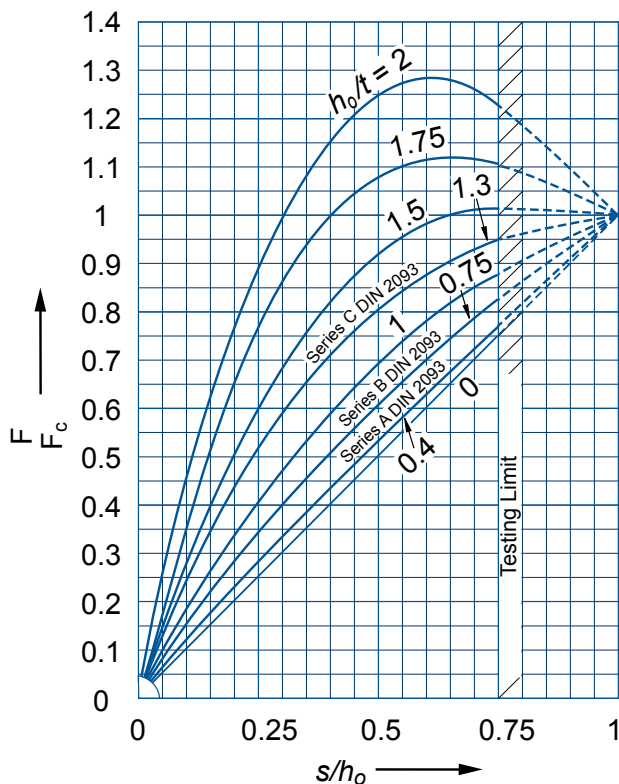

The load/deflection curve of a single Disc Spring is not linear. Its shape depends on the ratio of cone height (h_0) to the thickness (t) (h_0/t). If the ratio is small, 0.4 (DIN Series A), the characteristic is virtually a straight line. The load deflection becomes increasingly curved as the ratio h_0/t increases.

Up to a ratio of 1.5, Disc Springs may safely be taken to the flat position.

At a ratio of 1.5 the curve is flat for a considerable range of deflection. This is a useful consideration for wear compensation.

Above 1.5 the Disc Spring exhibits increasingly regressive characteristics and is capable of push-through and therefore needs to be fully supported.

At ratios over 2, the Disc Springs may invert when taken towards the flat position.

F_c is the design force of the Disc Spring in the flattened position.

CRITICAL STRESS POINTS

When the disc is loaded, compressive stresses result at Points I and IV. Compressive stresses typically act on the upper surface of the disc.

At the theoretical Point (O) between Points I and IV, the stress must not exceed the yield strength of the disc material (1400 – 1600 N/mm² for the DIN 2093 specified materials) to ensure that there will be no “set.”

Tensile stresses at Points II and III are the basis for fatigue life calculations. Tensile stresses typically act on the lower surface of the disc.

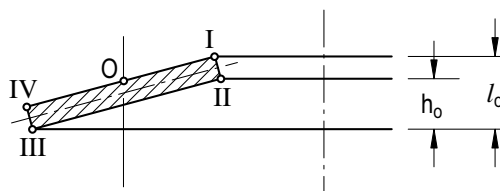

STATIC LOADING

Static loading is defined as carrying a constant load or an occasionally changing load at relatively long time intervals not exceeding ten thousand cycles per design life. In these cases the highest calculated stress at Point O is most critical and should not exceed 1400 – 1600 N/mm² in the flat ($s = h_0$) position for the DIN 2093 specified materials.

The standard range of Disc Springs may be used in static loading conditions without the need to perform theoretical stress calculations. Under these conditions, spring set is not a factor with stresses up to $F = 0.75 h_0$.

DYNAMIC LOADING

Residual manufacturing tensile stresses occur at the upper inside diameter edge Point I. These revert to compressive stresses when the disc is deflected by 15% to 20% of the total cone height (h_0). Fatigue life will be drastically reduced by stress reversals and therefore discs in dynamic applications must be preloaded by a minimum of 15% to 20%.

The maximum deflection limit of 75% of total deflection ($s = 0.75 h_0$) must be observed.

To increase fatigue life 1) reduce maximum stress, 2) increase pre-stress, or 3) both.

Dynamically loaded Disc Springs are generally divided into two categories:

1. Limited Life – Discs which should achieve 2×10^6 cycles without failure.
2. Practically Unlimited Life – Discs which should exceed 2×10^6 cycles without failure.

Detailed design calculations can be provided by **SPIROL** to determine estimated fatigue life. At a minimum, the following information is required:

1. Mounting space available
2. Maximum load
3. Type of load – static, intermittent, dynamic
4. Cycle life expected
5. Operating conditions – temperature, corrosion

FATIGUE LIFE

When determining fatigue life of a Disc Spring, it is necessary to know the forces and deflections of the disc at both points of its cycle. Tensile stresses are always the determining factor in causing failure due to fatigue, so evaluating the stresses at points II and III is required.

The charts below represent typical expected life of discs tested under laboratory conditions. To use these charts properly, it is necessary to determine the maximum stresses at both minimum and maximum deflection points of the disc. Because either point II or III may be the highest loaded, it is recommended that both be evaluated and the worst case used.

These values are based on laboratory testing using fatigue testing equipment producing sinusoidal loading cycles and resulting in a 99% probability of fatigue life. These figures are valid for single discs and stacks in series of 10 discs or fewer utilizing a 15%-20% preload. Cycling was performed at room temperature and at a rate not to induce significant heating utilizing hardened and highly polished surfaces and guidance.

Stacking discs in parallel greatly reduces fatigue life as individual disc deflections may be attenuated due to the mating disc, resulting in localized higher stresses.

These values only apply to DIN standard materials that are not shot peened. Shot peening discs can extend the fatigue life of certain discs, but testing is required to determine the exact benefit.

GROUP 1 $t < 1.25\text{mm}$

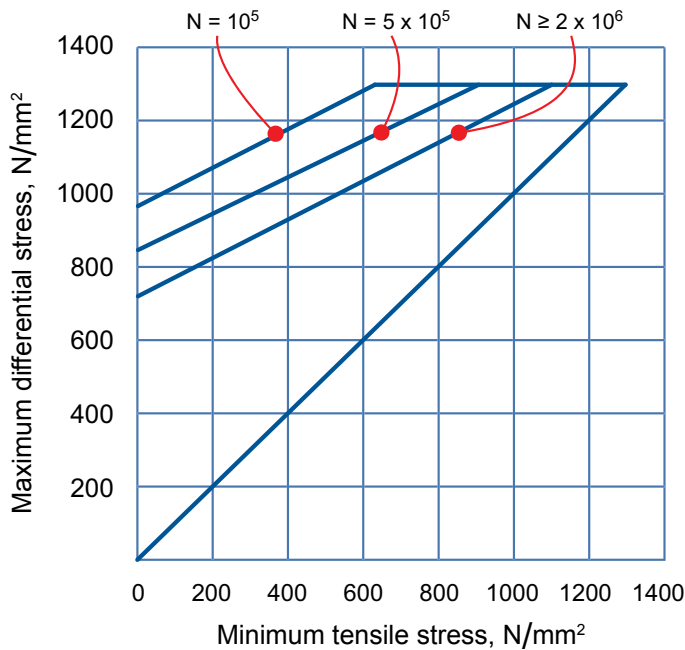

GROUP 2 $1.25\text{mm} \leq t \leq 6.0\text{mm}$

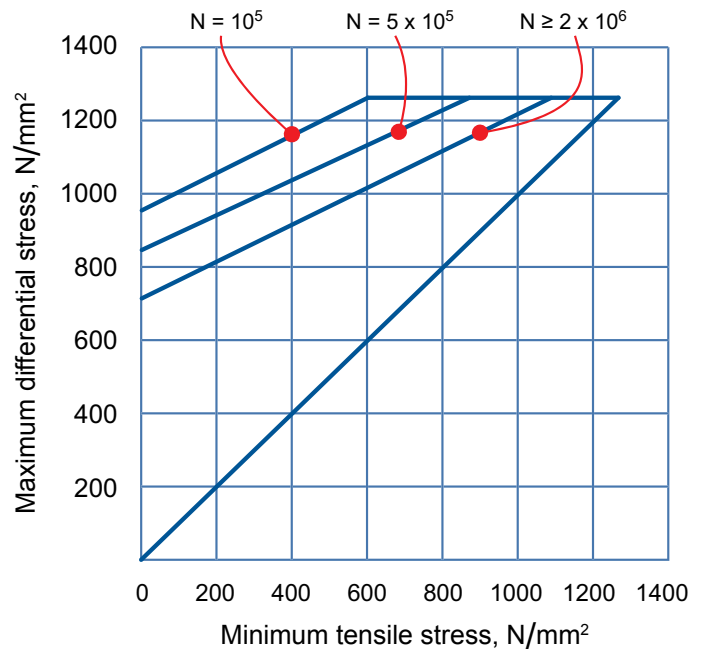

SIZING AND SELECTION

- Select the disc with the largest outside diameter (D_o). This reduces the stresses at a given force (F)/deflection (s) ratio and thus enhances fatigue life. An outside (D_o) to inside diameter (D_i) of 1.7 to 2.2 also enhances performance and longevity.
- Select a disc that achieves the maximum force required at less than 75% of its deflection. Deflection of 75% of cone height (h_o) should be the design maximum. Reducing deflection increases fatigue life.
- Force/deflection curves can be changed by varying the cone height (h_o) to thickness (t) ratio. Curves for discs may be plotted with the force/deflection data provided on pages 9-14 at 25%, 50%, 75% and 100% of deflection.
- Thicker discs have greater damping (hysteresis) characteristics.

ORIENTATION

- Shorter stacks are more efficient. This is particularly important under dynamic loading. Discs at the moving end of the stack are overdeflected whereas discs at the opposite end are underdeflected. This results from the friction between the individual discs as well as the discs and the guiding mandrel or sleeve. Use of the largest practical outside diameter discs will reduce the number of individual discs and total stack height. It is recommended that total stack height not exceed three times the external disc diameter (D_o) or ten total discs.
- When discs are used in parallel, the following factors should be considered:
 1. In dynamic applications, the generation of heat;
 2. The relationship between loading and unloading forces due to friction;
 3. Hysteresis, the increased damping resulting from friction between the discs; and
 4. Lubrication – A must in parallel disc applications.
- Lubrication is required for the efficient use and extended life of discs. In moderate applications, a solid lubricant such as molybdenum disulfide will generally suffice. In severe and corrosive applications, an oil or grease lubricant housed in a chamber may be required.
- Hardened thrust washers will alleviate surface damage/indentation when discs are used in conjunction with soft materials.

FATIGUE LIFE

- Fatigue life can be improved by increasing preload and reducing maximum deflection. This will likely require additional discs in series, but will extend life.
- Shot peening induces favorable compressive stresses on the disc surface. This reduces the likelihood of fatigue failure due to tensile stresses which generally start on the surface.
- Presetting is defined as a single or repeated compression of a heat treated disc to the flat condition. The strains induced give rise to plastic deformation, the spring thereby loses height. The remaining free conical height (h_o) results from the residual stresses being at an equilibrium of forces and moments. The disc will no longer plastically deform during subsequent loading. This allows for higher load stresses and longer fatigue life.

MATERIALS AND FINISHES

- High carbon and alloy steel materials provide excellent strength and endurance life in most applications. The standard coating of zinc phosphate and oil provides adequate protection from humidity and occasional moisture. More effective protective finishes are available, but these tend to wear off in dynamic applications.
- Electroplated finishes should always be avoided. Hydrogen embrittlement poses too great of a risk in highly loaded discs having a hardness over HRC 40.
- Austenitic stainless steel is a very good choice for static and low cycle applications. It provides high forces and excellent corrosion resistance. This material will continue to work harden with use so cycle life is limited, but creep resistance is good.
- For dynamic applications where corrosion protection is required, precipitation hardening stainless steels are recommended. These steels are nearly as strong as the standard DIN materials and very corrosion resistant.
- At temperatures over approximately 200°F (100°C), standard DIN materials can begin to creep, or take a set. Between 300°F and 400°F (150°C to 200°C) the materials lose their strength and are no longer considered viable. Stainless steels are a bit more temperature resistant, but only up to 575°F (300°C).

DISC SPRINGS – STACKING

STACKING

Stacking individual Disc Springs provides the designer with:

- A wide range of possible force/deflection combinations;
- The ability to design application specific load curves – both progressive and regressive; and
- The opportunity to design a range of dampening characteristics into the design.

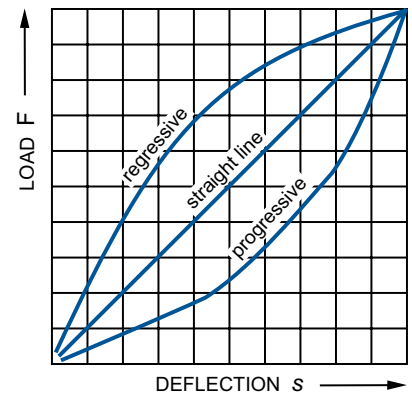

METHODS OF STACKING

IN PARALLEL

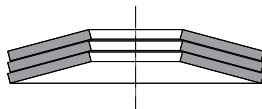

Deflection: Same as single disc

Force: Single disc multiplied by the number of discs

IN SERIES

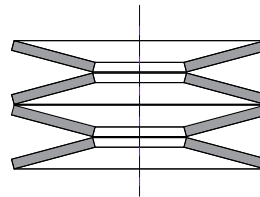

Deflection: Single disc multiplied by the number of discs

Force: Same as single disc

IN COMBINATION

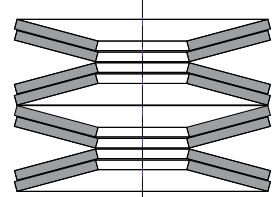

Deflection: Single disc multiplied by the number of discs in series

Force: Single disc multiplied by the number of parallel discs in a set

Consideration needs to be given to the friction between the parallel disc surfaces. A reasonable allowance is 2 - 3% of the force for each sliding surface – a greater force for loading and a lesser force for unloading. Discs in parallel should be well lubricated and it is suggested that the number of discs in a parallel set be limited to a maximum of 4 to reduce the deviation from calculated to measured characteristics. Discs in parallel have increased self-dampening (hysteresis) characteristics.

STACK CONSTRUCTION

EVEN NUMBER OF DISCS

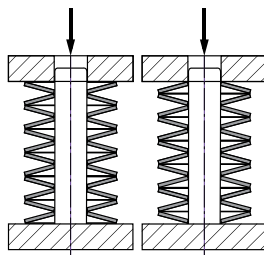

RIGHT **WRONG**

ODD NUMBER OF DISCS

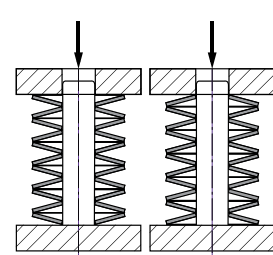

RIGHT **WRONG**

It is normally desirable to have both ends rest on the larger outer edge of the disc. With an uneven number of pairs in a stack, this is not possible. In this case, the end resting on the outer edge should be arranged to be on the end on which the force is applied – the moving end of the stack.

STACK GUIDANCE

Stacks need to be guided to keep the discs in position. The preferred method is internal, such as a rod through the inside diameter. In case of external guidance, a sleeve is suggested. In either case, the guiding component should be case-hardened to a depth of not less than 0.6mm and a hardness of 58 HRC. A surface finish of ≤ 4 microns is also recommended.

Since the diameter of the discs change when compressed, the following clearance values are recommended:

D_e or D_i (mm)	CLEARANCE (mm)
Up to 16	0.2
Over 16 to 20	0.3
Over 20 to 26	0.4
Over 26 to 31.5	0.5
Over 31.5 to 50	0.6
Over 50 to 80	0.8
Over 80 to 140	1.0
Over 140 to 250	1.6

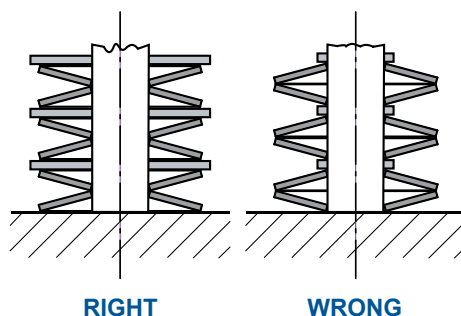

The stability of a disc with a thickness of 1mm or less can present a problem at the bearing surfaces. In such cases, the use of intermediate flat discs is recommended with outside diameter contact.

PROGRESSIVE LOAD CURVES

Progressive loading can be obtained by assembling stacks in which discs will deflect consecutively when loaded. Generally, this is done by 1) stacking single, double and triple parallel sets in series, or 2) stacking discs of various thickness in series. It is, however, necessary to provide a means to limit the compression of the weaker disc to avoid overstressing while the stronger discs are still in process of compression.

DISC STACKS WITH PROGRESSIVE CHARACTERISTIC LOAD CURVES AND STROKE LIMITERS TO AVOID OVERLOAD

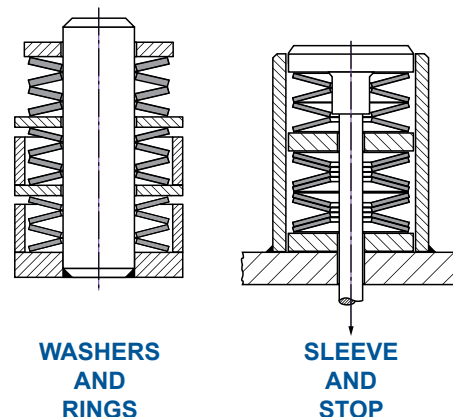

DIAMETER TOLERANCE

Outside Diameter: D_e h12
 Inside Diameter: D_i H12

Concentricity: $D_e \leq 50\text{mm}$ 2 • IT 11
 $D_e > 50\text{mm}$ 2 • IT 12

D_e or D_i RANGE mm	D_e TOLERANCE MINUS mm	D_i TOLERANCE PLUS mm	CONCENTRICITY TOLERANCE ¹
3 to 6	0.12	0.12	0.15
Over 6 to 10	0.15	0.15	0.18
Over 10 to 18	0.18	0.18	0.22
Over 18 to 30	0.21	0.21	0.26
Over 30 to 50	0.25	0.25	0.32
Over 50 to 80	0.30	0.30	0.60
Over 80 to 120	0.35	0.35	0.70
Over 120 to 180	0.40	0.40	0.80
Over 180 to 250	0.46	0.46	0.92

1) In reference to Outside Diameter D_e

THICKNESS TOLERANCE (t)

THICKNESS RANGE mm	TOLERANCE mm	
	PLUS	MINUS
From 0.2 to 0.6	0.02	0.06
Over 0.6 to under 1.25	0.03	0.09
From 1.25 to 3.8	0.04	0.12
Over 3.8 to 6	0.05	0.15

FREE OVER-ALL HEIGHT (l_o) TOLERANCE

THICKNESS RANGE (t) mm	TOLERANCE mm	
	PLUS	MINUS
Less than 1.25	0.10	0.05
From 1.25 to 2	0.15	0.08
Over 2 to 3	0.20	0.10
Over 3 to 6	0.30	0.15

SPRING FORCE TOLERANCE

The following deviations apply for normal applications:

The static load (F) of a single disc shall be determined for a disc in the loaded state using a suitable lubricant. The pressure plates between which the disc is compressed must be hardened, ground and polished.

THICKNESS (t) mm	PERMISSIBLE DEVIATION in load F at $s = 0.75 h_o$ as a percentage
Less than 1.25	+ 25 % - 7.5 %
From 1.25 to 3	+ 15 % - 7.5 %
Over 3 to 6	+ 10 % - 5 %

DISC SPRINGS TO DIN 2093

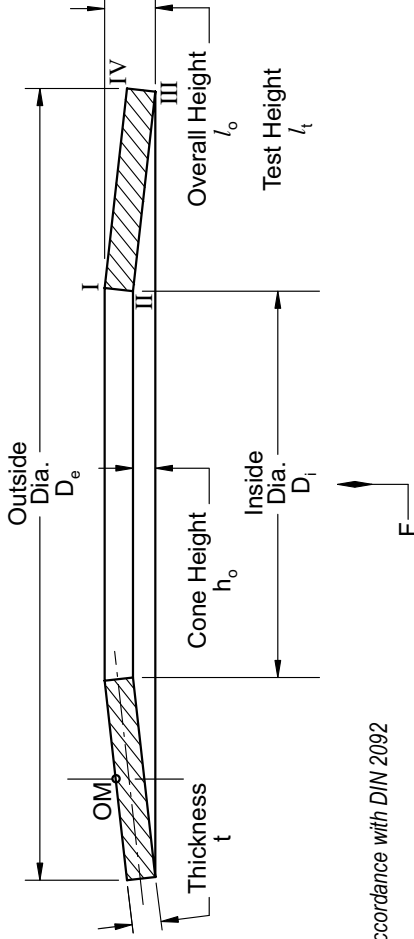

Deflection s in mm
 Force F in N
 Stress σ in N/mm²
 Values calculated in accordance with DIN 2092

TO ORDER: Product / $D_e \times D_i \times t$ / material code / finish code
 EXAMPLE: DSC 25 x 12.2 x 0.7 BR

STANDARD MATERIALS	
B	"t" less than 1.25mm High Carbon Steel HV 425 - 510 HRC 43 - 50
W	"t" 1.25mm and thicker Alloy Steel HV 412 - 544 HRC 42 - 52
STANDARD FINISH	
R	Phosphate coated, oiled

Refer to page 14 for SPIROL Stainless Steel Disc Springs.

DIN Series	Design Force, Deflection and Stresses Based on $E = 206 \text{ kN/mm}^2$ and $\mu = 0.3$																															
	Dimensions			Preload, $s = 0.15 h_o$			$s = 0.25 h_o$			$s = 0.5 h_o$			$s = 0.75 h_o$			$s = h_o$																
	D_e	D_i	t	l_o	h_o	h_o/t	s	l_t	F	σ_{II}	σ_{III}	s	l_t	F	σ_{II}	σ_{III}	s	l_t	F	σ_{II}	σ_{III}	s	l_t	F	σ_{II}	σ_{III}	s	l_t	F	σ_{II}	σ_{III}	
	8	3.2	0.3	0.55	0.25	0.83	0.04	0.51	31	122	263	0.06	0.49	44	197	386	0.13	0.42	81	540	775	0.19	0.36	105	930	1057	0.25	126	1332			
	8	3.2	0.4	0.60	0.20	0.50	0.03	0.57	43	212	214	0.05	0.55	69	365	350	0.10	0.50	130	792	666	0.15	0.45	186	1281	949	0.20	238	1421			
	8	3.2	0.5	0.70	0.20	0.40	0.03	0.67	79	299	249	0.05	0.65	128	511	408	0.10	0.60	246	1063	782	0.15	0.55	357	1717	1123	0.20	465	1776			
C	8	4.2	0.2	0.45	0.25	1.25	0.04	0.41	15	-6	269	0.06	0.39	21	6	394	0.13	0.32	34	127	778	0.19	0.26	39	329	1044	0.25	42	-1003			
B	8	4.2	0.3	0.55	0.25	0.83	0.04	0.51	35	107	328	0.06	0.49	50	175	482	0.13	0.42	92	493	971	0.19	0.36	119	865	1325	0.25	142	-1505			
A	8	4.2	0.4	0.60	0.20	0.50	0.03	0.57	48	198	268	0.05	0.55	78	343	439	0.10	0.50	147	749	837	0.15	0.45	210	1218	1194	0.20	269	-1605			
	10	3.2	0.3	0.65	0.35	1.17	0.05	0.60	32	36	223	0.09	0.56	52	95	388	0.18	0.47	83	324	714	0.26	0.39	98	640	951	0.35	108	-1147			
	10	3.2	0.5	0.85	0.35	0.70	0.05	0.80	99	240	289	0.09	0.76	169	461	506	0.18	0.67	303	1057	948	0.26	0.59	401	1700	1290	0.35	500	-1911			
	10	4.2	0.4	0.70	0.30	0.75	0.05	0.65	55	151	275	0.08	0.62	84	260	430	0.15	0.55	140	570	760	0.23	0.47	192	1019	1084	0.30	232	-1384			
	10	4.2	0.5	0.75	0.25	0.50	0.04	0.71	72	222	235	0.06	0.69	106	343	348	0.13	0.62	214	815	713	0.19	0.56	297	1280	992	0.25	377	-1441			
	10	4.2	0.6	0.85	0.25	0.42	0.04	0.81	118	296	266	0.06	0.79	175	453	394	0.13	0.72	360	1053	813	0.19	0.66	508	1629	1138	0.25	652	-1730			
C	10	5.2	0.25	0.55	0.30	1.20	0.05	0.50	22	4	260	0.08	0.47	32	26	403	0.15	0.40	48	133	702	0.23	0.32	58	352	980	0.30	63	-957			
B	10	5.2	0.4	0.70	0.30	0.75	0.05	0.65	61	139	330	0.08	0.62	93	242	516	0.15	0.55	155	539	912	0.23	0.47	213	974	1303	0.30	257	-1531			
A	10	5.2	0.5	0.75	0.25	0.50	0.04	0.71	80	212	283	0.06	0.69	117	328	418	0.13	0.62	236	784	858	0.19	0.56	329	1238	1195	0.25	418	-1595			
	12	4.2	0.4	0.80	0.40	1.00	0.06	0.74	55	76	238	0.10	0.70	85	149	385	0.20	0.60	141	411	714	0.30	0.50	178	786	988	0.40	206	-1228			
	12	4.2	0.5	0.90	0.40	0.80	0.06	0.84	91	188	266	0.10	0.80	143	285	432	0.20	0.70	249	683	809	0.30	0.60	331	1193	1130	0.40	402	-1535			
	12	5.2	0.5	0.90	0.40	0.80	0.06	0.84	96	137	303	0.10	0.80	150	251	493	0.20	0.70	263	611	923	0.30	0.60	350	1080	1291	0.40	424	-1619			
	12	5.2	0.6	0.95	0.35	0.58	0.05	0.90	116	202	266	0.09	0.86	201	384	467	0.18	0.77	370	856	884	0.26	0.69	502	1350	1213	0.35	641	-1700			
	12	6.2	0.5	0.85	0.35	0.70	0.05	0.80	80	132	278	0.09	0.76	137	257	487	0.18	0.67	245	604	917	0.26	0.59	324	988	1249	0.35	404	-1544			
	12	6.2	0.6	0.95	0.35	0.58	0.05	0.90	127	194	310	0.09	0.86	219	369	545	0.18	0.77	403	829	1033	0.26	0.69	547	1313	1417	0.35	699	-1853			

DISC SPRINGS TO DIN 2093

DIN Series	Dimensions												Design Force, Deflection and Stresses Based on E = 206 kN/mm ² and μ = 0.3																																			
	D _e	D _i	t	l _o	h _o	h _o /t	Preload, s = 0.15 h _o						s = 0.25 h _o						s = 0.5 h _o						s = 0.75 h _o						s = h _o																	
							s	l _t	F	σ _{III}	σ _{II}	σ _{III}	s	l _t	F	σ _{III}	σ _{II}	σ _{III}	s	l _t	F	σ _{III}	σ _{II}	σ _{III}	s	l _t	F	σ _{III}	σ _{II}	σ _{III}	s	l _t	F	σ _{III}	σ _{II}	σ _{III}	s	l _t	F	σ _{III}	σ _{II}	σ _{III}						
C	12.5	6.2	0.35	0.80	0.45	1.29	0.07	0.73	57	-14	325	0.11	0.69	82	1	496	0.23	0.57	131	142	949	0.34	0.46	152	401	1284	0.45	160	-1250																			
B	12.5	6.2	0.5	0.85	0.35	0.70	0.05	0.80	72	122	246	0.09	0.76	123	238	431	0.18	0.67	220	569	811	0.26	0.59	291	913	1105	0.35	363	-1388																			
A	12.5	6.2	0.7	1.00	0.30	0.43	0.05	0.95	162	263	287	0.08	0.92	255	432	452	0.15	0.85	457	864	814	0.23	0.77	673	1419	1189	0.30	855	-1666																			
C	14	7.2	0.35	0.80	0.45	1.29	0.07	0.73	46	-12	268	0.11	0.69	67	-2	409	0.23	0.57	107	109	784	0.34	0.46	123	315	1061	0.45	131	-1018																			
B	14	7.2	0.5	0.90	0.40	0.80	0.06	0.84	76	94	258	0.10	0.80	120	173	419	0.20	0.70	210	428	787	0.30	0.60	279	764	1101	0.40	338	-1293																			
A	14	7.2	0.8	1.10	0.30	0.38	0.05	1.05	192	255	261	0.08	1.02	302	418	411	0.15	0.95	547	826	743	0.23	0.87	813	1341	1092	0.30	1040	-1551																			
	15	5.2	0.4	0.95	0.55	1.38	0.08	0.87	66	-15	242	0.14	0.81	103	4	408	0.28	0.67	156	149	746	0.41	0.54	175	411	998	0.55	181	-1079																			
	15	5.2	0.7	1.25	0.55	0.79	0.08	1.17	210	194	314	0.14	1.11	346	370	535	0.28	0.97	605	882	1000	0.41	0.84	793	1483	1370	0.55	969	-1888																			
	15	6.2	0.5	1.00	0.50	1.00	0.08	0.92	95	70	278	0.13	0.87	143	137	439	0.25	0.75	229	368	787	0.38	0.62	291	732	1100	0.50	334	-1275																			
	15	6.2	0.6	1.05	0.45	0.75	0.07	0.98	116	141	255	0.11	0.94	174	236	392	0.23	0.82	320	591	766	0.34	0.71	426	1005	1060	0.45	519	-1377																			
	15	6.2	0.7	1.10	0.40	0.57	0.06	1.04	138	189	228	0.10	1.00	222	328	373	0.20	0.90	411	727	707	0.30	0.80	578	1195	1002	0.40	733	-1428																			
	15	8.2	0.7	1.10	0.40	0.57	0.06	1.04	159	178	293	0.10	1.00	256	311	479	0.20	0.90	474	694	909	0.30	0.80	666	1150	1291	0.40	844	-1646																			
	15	8.2	0.8	1.20	0.40	0.50	0.06	1.14	226	226	320	0.10	1.10	367	391	523	0.20	1.00	689	856	997	0.30	0.90	982	1392	1423	0.40	1261	-1881																			
C	16	8.2	0.4	0.90	0.50	1.25	0.08	0.82	58	-5	262	0.13	0.77	86	12	413	0.25	0.65	131	117	735	0.38	0.52	155	332	1018	0.50	165	-988																			
B	16	8.2	0.6	1.05	0.45	0.75	0.07	0.98	112	114	267	0.11	0.94	169	192	411	0.23	0.82	309	488	805	0.34	0.71	412	838	1115	0.45	503	-1333																			
A	16	8.2	0.9	1.25	0.35	0.39	0.05	1.20	211	215	227	0.09	1.16	372	398	401	0.18	1.07	716	846	771	0.26	0.99	1004	1287	1071	0.35	1319	-1555																			
	18	6.2	0.4	1.00	0.60	1.50	0.09	0.91	57	-32	198	0.15	0.85	85	-30	319	0.30	0.70	126	52	583	0.45	0.55	139	247	791	0.60	137	-816																			
	18	6.2	0.5	1.10	0.60	1.20	0.09	1.01	85	23	217	0.15	0.95	130	61	350	0.30	0.80	206	234	646	0.45	0.65	245	520	885	0.60	267	-1021																			
	18	6.2	0.6	1.20	0.60	1.00	0.09	1.11	124	78	236	0.15	1.05	191	152	382	0.30	0.90	317	416	708	0.45	0.75	400	794	980	0.60	462	-1225																			
	18	6.2	0.7	1.40	0.70	1.00	0.11	1.29	239	112	335	0.18	1.22	362	215	533	0.35	1.05	588	567	964	0.53	0.87	745	1097	1343	0.70	855	-1667																			
	18	6.2	0.8	1.50	0.70	0.88	0.11	1.39	320	179	358	0.18	1.32	491	324	571	0.35	1.15	822	779	1037	0.53	0.97	1078	1419	1454	0.70	1277	-1905																			
	18	8.2	0.7	1.25	0.55	0.79	0.08	1.17	157	114	259	0.14	1.11	259	220	442	0.28	0.97	452	536	827	0.41	0.84	594	914	1135	0.55	725	-1412																			
	18	8.2	0.8	1.30	0.50	0.63	0.08	1.22	205	178	268	0.13	1.17	320	306	427	0.25	1.05	564	660	777	0.38	0.92	791	1124	1110	0.50	984	-1468																			
	18	8.2	1	1.50	0.50	0.50	0.08	1.42	367	268	309	0.13	1.37	580	451	493	0.25	1.25	1051	939	904	0.38	1.12	1514	1547	1303	0.50	1921	-1834																			
C	18	9.2	0.45	1.05	0.60	1.33	0.09	0.96	80	-22	272	0.15	0.90	121	-14	440	0.30	0.75	186	83	809	0.45	0.60	214	291	1106	0.60	223	-1052																			
B	18	9.2	0.7	1.20	0.50	0.71	0.08	1.12	156	129	275	0.13	1.07	242	226	436	0.25	0.95	417	509	792	0.38	0.82	572	895	1126	0.50	699	-1363																			
A	18	9.2	1	1.40	0.40	0.40	0.06	1.34	276	223	240	0.10	1.30	451	382	394	0.20	1.20	865	814	757	0.30	1.10	1254	1295	1088	0.40	1631	-1558																			
	20	8.2	0.6	1.30	0.70	1.17	0.11	1.19	146	25	279	0.18	1.12	219	66	443	0.35	0.95	342	246	797	0.53	0.77	413	560	1103	0.70	453	-1202																			
	20	8.2	0.7	1.35	0.65	0.93	0.10	1.25	172	87	263	0.16	1.19	258	158	410	0.33	1.02	447	436	785	0.49	0.86	570	802	1080	0.65	688	-1302																			
	20	8.2	0.8	1.40	0.60	0.75	0.09	1.31	199	136	245	0.15	1.25	315	244	398	0.30	1.10	557	576	748	0.45	0.95	751	998	1048	0.60	921	-1373																			
	20	8.2	0.9	1.50	0.60	0.67	0.09	1.41	265	177	262	0.15	1.35	423	313	427	0.30	1.20	765	715	804	0.45	1.05	1051	1205	1133	0.60	1311	-1545																			
C	20	10.2	0.5	1.15	0.65	1.30	0.10	1.05	96	-15	288	0.16	0.99	140	-5	416	0.33	0.82	221	102	786	0.49	0.66	254	309	1067	0.65	268	-1024																			
B	20	10.2	0.8	1.35	0.55	0.69	0.08	1.27	166	125	251	0.14	1.21	309	235	428	0.28	1.07	555	548	806	0.41	0.94	745	909	1112	0.55	929	-1366																			
	20	10.2	0.9	1.45	0.55	0.61	0.08	1.37	249	161	269	0.14	1.31	419	298	460	0.28	1.17	765	674	870	0.41	1.04	1045	1094	1206	0.55	1323	-1560																			
	20	10.2	1	1.55	0.55	0.55	0.08	1.47	327	197	287	0.14	1.41	553	361	492	0.28	1.27	1026	800	934	0.41	1.14	1418	1278	1300	0.55	1815	-1733																			
A	20	10.2	1.1	1.55	0.45	0.41	0.07	1.48	347	230	251	0.11	1.44	537	370	388	0.23	1.32	1072	830	776	0.34	1.21	1531	1200	1301	0.45	1976	-1560																			
C	22.5	11.2	0.6	1.40	0.80	1.33	0.12	1.28	160	-23	302	0.20	1.20	240	-14	488	0.40	1.00	370	98	787	0.60	0.80	820	1025	336	1227	0.80	444	-1178																		
B	22.5	11.2	0.8	1.45	0.65	0.81	0.10	1.35	199	96	260	0.16	1.29	302	168	406	0.33	1.12	539	434	782	0.49	0.96	710	768	1083	0.65	855	-1276																			
A	22.5	11.2	1.25	1.75	0.50	0.40	0.08	1.67	451	239	249	0.13	1.62	720	399	398	0.25	1.50	1330	815	737	0.38	1.37	1952	1316	1071	0.50	2509	-1534																			

DISC SPRINGS TO DIN 2093

DIN Series	Dimensions											Design Force, Deflection and Stresses Based on $E = 206 \text{ kN/mm}^2$ and $\mu = 0.3$																	
	D_e	D_i	t	l_0	h_0	h_o/t	Preload, $s = 0.15 h_0$				$s = 0.25 h_0$				$s = 0.5 h_0$				$s = 0.75 h_0$				$s = h_0$						
							s	l_f	F	σ_{hi}	σ_{mh}	s	l_f	F	σ_{hi}	σ_{mh}	s	l_f	F	σ_{hi}	σ_{mh}	s	l_f	F	σ_{hi}	σ_{mh}	s	l_f	F
	23	8.2	0.7	1.50	0.80	1.14	0.12	1.38	183	37	245	0.20	1.30	279	87	397	0.40	1.10	448	295	733	0.60	0.90	544	626	1007	0.80	602	-1173
	23	8.2	0.8	1.55	0.75	0.94	0.11	1.44	209	90	232	0.19	1.36	336	178	389	0.38	1.17	565	466	722	0.56	0.99	717	840	988	0.75	842	-1257
	23	8.2	0.9	1.70	0.80	0.89	0.12	1.58	311	125	277	0.20	1.50	486	233	449	0.40	1.30	829	589	837	0.60	1.10	1078	1066	1164	0.80	1279	-1508
	23	10.2	0.9	1.65	0.75	0.83	0.11	1.54	289	113	282	0.19	1.46	468	217	475	0.38	1.27	810	541	887	0.56	1.09	1055	947	1221	0.75	1273	-1500
	23	10.2	1	1.70	0.70	0.70	0.11	1.59	353	167	290	0.18	1.52	552	291	463	0.35	1.35	964	655	849	0.53	1.17	1325	1133	1204	0.70	1629	-1556
	23	12.2	1.25	1.85	0.60	0.48	0.09	1.76	532	231	304	0.15	1.70	863	399	497	0.30	1.55	1630	868	949	0.45	1.40	2331	1404	1356	0.60	3000	-1834
	23	12.2	1.5	2.10	0.60	0.40	0.09	2.01	875	308	344	0.15	1.95	1432	527	565	0.30	1.80	2748	1124	1085	0.45	1.65	3986	1788	1560	0.60	5184	-2200
C	25	12.2	0.7	1.60	0.90	1.29	0.14	1.46	226	-13	320	0.23	1.37	337	5	509	0.45	1.15	515	136	919	0.68	0.92	601	403	1265	0.90	635	-1238
B	25	12.2	0.9	1.60	0.70	0.78	0.11	1.49	243	105	250	0.18	1.42	376	187	400	0.35	1.25	644	440	730	0.53	1.07	868	787	1031	0.70	1050	-1238
A	25	12.2	1.5	2.05	0.55	0.37	0.08	1.97	615	242	232	0.14	1.91	1058	433	400	0.28	1.77	2041	916	769	0.41	1.64	2910	1410	1085	0.55	3821	-1622
	28	10.2	0.8	1.75	0.95	1.19	0.14	1.61	225	23	228	0.24	1.51	351	63	379	0.48	1.27	556	244	698	0.71	1.04	661	528	947	0.95	723	-1078
	28	10.2	1	2.00	1.00	1.00	0.15	1.85	398	84	278	0.25	1.75	615	165	451	0.50	1.50	1022	459	837	0.75	1.25	1289	880	1158	1.00	1486	-1419
	28	10.2	1.25	2.25	1.00	0.80	0.15	2.10	654	176	312	0.25	2.00	1030	319	507	0.50	1.75	1799	765	949	0.75	1.50	2394	1340	1326	1.00	2902	-1774
	28	10.2	1.5	2.20	0.70	0.47	0.11	2.09	645	259	221	0.18	2.02	1030	437	356	0.35	1.85	1899	911	660	0.53	1.67	2745	1478	950	0.70	3511	-1490
	28	12.2	1	1.95	0.95	0.95	0.14	1.81	374	78	283	0.24	1.71	595	158	472	0.48	1.47	999	432	878	0.71	1.24	1266	802	1204	0.95	1482	-1415
	28	12.2	1.25	2.10	0.85	0.68	0.13	1.97	539	173	282	0.21	1.89	835	296	446	0.43	1.67	1534	701	858	0.64	1.46	2089	1178	1200	0.85	2590	-1583
	28	12.2	1.5	2.25	0.75	0.50	0.11	2.14	694	230	255	0.19	2.06	1163	412	432	0.38	1.87	2185	897	822	0.56	1.69	3065	1423	1153	0.75	3949	-1676
C	28	14.2	0.8	1.80	1.00	1.25	0.15	1.65	287	-7	319	0.25	1.55	435	13	515	0.50	1.30	681	154	950	0.75	1.05	801	422	1304	1.00	859	-1282
B	28	14.2	1	1.80	0.80	0.80	0.12	1.68	303	94	254	0.20	1.60	476	174	414	0.40	1.40	832	429	776	0.60	1.20	1107	765	1086	0.80	1342	-1282
	28	14.2	1.25	2.10	0.85	0.68	0.13	1.97	580	165	321	0.21	1.89	898	283	508	0.43	1.67	1649	677	978	0.64	1.46	2246	1144	1369	0.85	2785	-1702
A	28	14.2	1.5	2.15	0.65	0.43	0.10	2.05	649	222	252	0.16	1.99	1018	365	397	0.33	1.82	1997	809	783	0.49	1.66	2854	1281	1111	0.65	3680	-1562
C	31.5	16.3	0.8	1.85	1.05	1.31	0.16	1.69	258	-19	282	0.26	1.59	382	-9	444	0.53	1.32	597	97	831	0.79	1.06	687	310	1132	1.05	722	-1077
B	31.5	16.3	1.25	2.15	0.90	0.72	0.14	2.01	515	130	285	0.23	1.92	806	230	458	0.45	1.70	1409	530	844	0.68	1.47	1923	927	1194	0.90	2359	-1442
	31.5	16.3	1.5	2.40	0.90	0.60	0.14	2.26	812	193	318	0.23	2.17	1286	334	512	0.45	1.95	2314	734	950	0.68	1.72	3249	1235	1354	0.90	4077	-1730
A	31.5	16.3	1.75	2.45	0.70	0.40	0.11	2.34	890	235	255	0.18	2.27	1429	394	410	0.35	2.10	2669	814	766	0.53	1.92	3905	1310	1111	0.70	5036	-1570
	31.5	16.3	2	2.75	0.75	0.38	0.11	2.64	1313	276	286	0.19	2.56	2227	488	486	0.38	2.37	4292	1035	935	0.56	2.19	6148	1607	1326	0.75	8054	-1923
	34	12.3	1	2.20	1.20	1.20	0.18	2.02	386	22	249	0.30	1.90	587	63	403	0.60	1.60	930	250	742	0.90	1.30	1110	563	1018	1.20	1208	-1153
	34	12.3	1.25	2.45	1.20	0.96	0.18	2.27	610	98	276	0.30	2.15	946	188	448	0.60	1.85	1587	500	833	0.90	1.55	2024	938	1154	1.20	2359	-1442
	34	12.3	1.5	2.70	1.20	0.80	0.18	2.52	919	173	304	0.30	2.40	1447	313	493	0.60	2.10	2527	750	923	0.90	1.80	3363	1313	1290	1.20	4076	-1730
	34	14.3	1.25	2.40	1.15	0.92	0.17	2.23	579	91	280	0.29	2.11	919	179	464	0.58	1.82	1555	472	865	0.86	1.54	1990	864	1190	1.15	2347	-1435
	34	14.3	1.5	2.55	1.05	0.70	0.16	2.39	781	170	279	0.26	2.29	1213	294	443	0.53	2.02	2209	696	848	0.79	1.76	2997	1177	1186	1.05	3704	-1572
	34	16.3	1.5	2.55	1.05	0.70	0.16	2.39	824	161	309	0.26	2.29	1280	280	491	0.53	2.02	2330	668	941	0.79	1.76	3163	1136	1316	1.05	3908	-1658
	34	16.3	2	2.85	0.85	0.43	0.13	2.72	1309	265	279	0.21	2.64	2073	439	444	0.43	2.42	4046	964	870	0.64	2.21	5803	1527	1238	0.85	7498	-1790
C	35.5	18.3	0.9	2.05	1.15	1.28	0.17	1.88	299	-12	261	0.29	1.76	461	2	430	0.58	1.47	716	111	792	0.86	1.19	831	318	1076	1.15	884	-1042
B	35.5	18.3	1.25	2.25	1.00	0.80	0.15	2.10	464	91	251	0.25	2.00	731	168	409	0.50	1.75	1277	416	766	0.75	1.50	1699	743	1073	1.00	2059	-1258
A	35.5	18.3	2	2.80	0.80	0.40	0.12	2.68	1139	240	249	0.20	2.60	1864	393	409	0.40	2.40	3576	837	750	0.60	2.20	5187	1332	1128	0.80	6747	-1611
	40	14.3	1.25	2.65	1.40	1.12	0.21	2.44	591	44	251	0.35	2.30	904	98	406	0.70	1.95	1459	319	750	1.05	1.60	1780	664	1033	1.40	1984	-1213
	40	14.3	1.5	2.80	1.30	0.87	0.20	2.60	777	122	251	0.33	2.47	1204	222	404	0.65	2.15	2040	542	743	0.98	1.82	2677	981	1038	1.30	3184	-1351
	40	14.3	2	3.05	1.05	0.53	0.16	2.89	1129	231	217	0.26	2.79	1784	389	346	0.53	2.52	3391	865	669	0.79	2.26	4781	1392	946	1.05	6096	-1455

DISC SPRINGS TO DIN 2093

Design Force, Deflection and Stresses Based on E = 206 kN/mm² and μ = 0.3

DIN Series		Dimensions								Preload, $s = 0.15 h_0$			$s = 0.25 h_0$			$s = 0.5 h_0$			$s = 0.75 h_0$			$s = h_0$													
		D_e	D_i	t	l_0	h_0	h_0/t	s	l_f	F	σ_{Hi}	σ_{HII}	s	l_f	F	σ_{Hi}	σ_{HII}	s	l_f	F	σ_{Hi}	σ_{HII}	s	l_f	F	σ_{Hi}	σ_{HII}	s	l_f	F	σ_{Hi}	σ_{HII}	s	l_f	F
		40	16.3	1.5	2.80	1.30	0.87	0.20	2.60	801	110	271	0.33	2.47	1240	203	436	0.65	2.15	2102	503	802	0.98	1.82	2758	918	1122	1.30	3281	-1392					
		40	16.3	2	3.10	1.10	0.55	0.17	2.93	1267	223	254	0.28	2.82	2005	383	409	0.55	2.55	3663	825	764	0.83	2.27	5195	1090	1122	1.30	6580	-1571					
		40	18.3	2	3.15	1.15	0.58	0.17	2.98	1337	206	281	0.29	2.86	2199	368	469	0.58	2.57	4060	819	890	0.86	2.29	5642	1333	1249	1.15	7171	-1712					
C		40	20.4	1	2.30	1.30	1.30	0.20	2.10	383	-15	268	0.33	1.97	572	-3	428	0.65	1.65	876	98	776	0.98	1.32	1018	309	1067	1.30	1072	-1024					
B		40	20.4	1.5	2.65	1.15	0.77	0.17	2.48	693	106	261	0.29	2.36	1117	198	435	0.58	2.07	1966	480	816	0.86	1.79	2616	831	1134	1.15	3201	-1359					
		40	20.4	2	3.10	1.10	0.55	0.17	2.93	1386	210	305	0.28	2.82	2211	361	492	0.55	2.55	4041	783	920	0.83	2.27	5730	1298	1314	1.10	7258	-1733					
A		40	20.4	2.25	3.15	0.90	0.40	0.14	3.01	1479	238	255	0.23	2.92	2385	401	412	0.45	2.70	4481	835	774	0.68	2.47	6544	1339	1120	0.90	8456	-1595					
		40	20.4	2.5	3.45	0.95	0.38	0.14	3.31	2010	270	279	0.24	3.21	3385	475	471	0.48	2.97	6516	1008	905	0.71	2.74	9359	1573	1286	0.95	12243	-1871					
C		45	22.4	2.5	2.85	1.60	1.28	0.24	2.61	689	-13	307	0.40	2.45	1041	4	497	0.80	2.05	1620	134	914	1.20	1.65	1891	389	1253	1.60	2007	-1227					
B		45	22.4	1.75	3.05	1.30	0.74	0.20	2.85	985	122	273	0.33	2.72	1544	218	440	0.65	2.40	2701	512	814	0.98	2.07	3659	898	1148	1.30	4475	-1396					
A		45	22.4	2.5	3.50	1.00	0.40	0.15	3.35	1695	224	234	0.25	3.25	2773	383	384	0.50	3.00	5320	815	737	0.75	2.75	7716	1296	1059	1.00	10037	-1534					
		50	18.4	1.5	3.15	1.65	1.10	0.25	2.90	768	43	231	0.41	2.74	1161	92	368	0.83	2.32	1897	297	687	1.24	1.91	2321	607	943	1.65	2600	-1104					
		50	18.4	2	3.65	1.65	0.83	0.25	3.40	1432	139	266	0.41	3.24	2218	249	426	0.83	2.82	3885	615	804	1.24	2.41	5121	1082	1118	1.65	6163	-1471					
		50	18.4	2.5	4.15	1.65	0.66	0.25	3.90	2447	235	301	0.41	3.74	3849	406	483	0.83	3.32	7037	933	921	1.24	2.91	9658	1557	1293	1.65	12038	-1839					
		50	20.4	2	3.50	1.50	0.75	0.23	3.27	1288	139	249	0.38	3.12	1989	248	402	0.75	2.75	3478	578	745	1.13	2.37	4702	1006	1048	1.50	5745	-1371					
		50	20.4	2.5	3.85	1.35	0.54	0.20	3.65	1840	212	238	0.34	3.51	3028	376	396	0.68	3.17	5637	825	751	1.01	2.84	7902	1330	1058	1.35	10098	-1543					
		50	22.4	2	3.60	1.60	0.80	0.24	3.36	1427	125	286	0.40	3.20	2247	228	466	0.80	2.80	3924	566	872	1.20	2.40	5222	985	1220	1.60	6329	-1511					
		50	22.4	2.5	3.90	1.40	0.56	0.21	3.69	2023	209	270	0.35	3.55	3261	364	442	0.70	3.20	6044	806	838	1.05	2.85	8510	1324	1190	1.40	10817	-1663					
C		50	25.4	1.25	2.85	1.60	1.28	0.24	2.61	585	-11	254	0.40	2.45	854	2	410	0.80	2.05	1328	106	755	1.20	1.65	1550	312	1035	1.60	1646	-1006					
		50	25.4	1.5	3.10	1.60	1.07	0.24	2.86	808	32	276	0.40	2.70	1242	74	447	0.80	2.30	2028	250	828	1.20	1.90	2512	528	1145	1.60	2844	-1207					
B		50	25.4	2	3.40	1.40	0.70	0.21	3.19	1226	128	264	0.35	3.05	1949	230	430	0.70	2.70	3491	537	810	1.05	2.35	4762	923	1140	1.40	5898	-1408					
		50	25.4	2.25	3.75	1.50	0.67	0.23	3.52	1859	169	318	0.38	3.37	2940	297	515	0.75	3.00	5249	675	959	1.13	2.62	7241	1154	1358	1.50	8997	-1697					
		50	25.4	2.5	3.90	1.40	0.56	0.21	3.69	2194	204	302	0.35	3.55	3473	355	494	0.70	3.20	6437	789	938	1.05	2.85	9063	1301	1332	1.40	11519	-1760					
A		50	25.4	3	4.10	1.10	0.37	0.17	3.93	2671	257	256	0.28	3.82	4329	432	416	0.55	3.55	8214	897	787	0.83	3.27	12044	1428	1141	1.10	15640	-1659					
C		56	28.5	1.5	3.45	1.95	1.30	0.29	3.16	959	-17	297	0.49	2.96	1464	-4	485	0.98	2.47	2265	114	893	1.46	1.99	2621	348	1217	1.95	2766	-1174					
B		56	28.5	2	3.60	1.60	0.80	0.24	3.36	1213	94	255	0.40	3.20	1910	173	415	0.80	2.80	3335	428	778	1.20	2.40	4438	765	1090	1.60	5379	-1284					
A		56	28.5	3	4.30	1.30	0.43	0.20	4.10	2602	222	253	0.33	3.97	4203	377	410	0.65	3.65	7895	795	775	0.98	3.32	11441	1281	1115	1.30	14752	-1565					
		60	20.5	2	4.20	2.20	1.10	0.33	3.87	1650	58	272	0.55	3.65	2528	125	440	1.10	3.10	4097	366	812	1.65	2.55	5026	784	1119	2.20	5636	-1346					
		60	20.5	2.5	4.70	2.20	0.88	0.33	4.37	2657	149	303	0.55	4.15	4151	276	491	1.10	3.60	7102	688	916	1.65	3.05	9255	1237	1273	2.20	11008	-1682					
		60	25.5	2.5	4.40	1.90	0.76	0.29	4.10	2216	146	282	0.48	3.92	3478	262	456	0.95	3.45	6081	616	847	1.43	2.97	8195	1078	1190	1.90	9997	-1527					
		60	25.5	3	4.65	1.65	0.55	0.25	4.40	2812	215	256	0.41	4.24	4470	367	412	0.83	3.82	8396	818	791	1.24	3.41	11803	1334	1119	1.65	15002	-1592					
		60	30.5	2.5	4.50	2.00	0.80	0.30	4.20	2578	128	347	0.50	4.00	4059	236	564	1.00	3.50	7088	583	1058	1.50	3.00	9432	1041	1481	2.00	11433	-1747					
		60	30.5	3	4.70	1.70	0.57	0.26	4.44	3213	208	313	0.43	4.27	5137	361	508	0.85	3.85	9407	793	953	1.28	3.42	13269	1316	1358	1.70	16792	-1782					
		60	30.5	3.5	5.00	1.50	0.43	0.23	4.77	4126	261	294	0.38	4.62	6674	443	478	0.75	4.25	12574	937	905	1.13	3.87	18225	1507	1302	1.50	23528	-1834					
C		63	31	1.8	4.15	2.35	1.31	0.35	3.80	1557	-19	330	0.59	3.56	2371	-4	538	1.18	2.97	3665	132	990	1.76	2.39	4237	400	1349	2.35	4463	-1315					
B		63	31	2.5	4.25	1.75	0.70	0.26	3.99	1834	126	250	0.44	3.81	2957	229	412	0.88	3.37	5294	535	777	1.31	2.94	7179	909	1086	1.75	8904	-1360					
		63	31	3	4.70	1.70	0.57	0.26	4.44	2860	190	275	0.43	4.27	4573	329	446	0.85	3.85	8373	721	838	1.28	3.42	11810	1196	1193	1.70	14946	-1586					
A		63	31	3.5	4.90	1.40	0.40	0.21	4.69	3301	224	231	0.35	4.55	5399	383	380	0.70	4.20	10359	815	729	1.05	3.85	15025	1296	1047	1.40	19545	-1524					
		70	30.5	2.5	4.90	2.40	0.96	0.36	4.54	2421	78	293	0.60	4.30	3755	153	475	1.20	3.70	6297	422	883	1.80	3.10	8031	806	1225	2.40	9360	-1430					

DISC SPRINGS TO DIN 2093

DIN Series	Design Force, Deflection and Stresses Based on $E = 206 \text{ kN/mm}^2$ and $\mu = 0.3$																													
	Dimensions					Preload, $s = 0.15 h_0$			$s = 0.25 h_0$			$s = 0.5 h_0$			$s = 0.75 h_0$			$s = h_0$												
	D_e	D_i	t	l_0	h_0	h_0/t	s	l_t	F	σ_{II}	σ_{III}	s	l_t	F	σ_{II}	σ_{III}	s	l_t	F	σ_{II}	σ_{III}	s	l_t	F	σ_{II}	σ_{III}	s	l_t	F	σ_{II}
	70	30.5	3	5.10	2.10	0.70	0.32	4.78	2984	168	270	0.53	4.57	4715	279	436	1.05	4.05	8376	640	814	1.58	3.52	11453	1097	1148	2.10	14152	-1502	
	70	35.5	3	5.10	2.10	0.70	0.32	4.78	3209	160	307	0.53	4.57	5070	267	497	1.05	4.05	9007	617	928	1.58	3.52	12316	1065	1310	2.10	15218	-1615	
	70	35.5	4	5.80	1.80	0.45	0.27	5.53	5376	250	294	0.45	5.35	8757	430	482	0.90	4.90	16634	925	921	1.35	4.45	23923	1486	1319	1.80	30919	-1845	
C	71	36	2	4.60	2.60	1.30	0.39	4.21	1895	-19	330	0.65	3.95	2861	-5	532	1.30	3.30	4432	125	980	1.95	2.65	5144	388	1342	2.60	5426	-1295	
B	71	36	2.5	4.50	2.00	0.80	0.30	4.20	1838	92	247	0.50	4.00	2894	169	402	1.00	3.50	5054	417	754	1.50	3.00	6725	744	1055	2.00	8152	-1246	
A	71	36	4	5.60	1.60	0.40	0.24	5.36	4511	230	245	0.40	5.20	7379	393	402	0.80	4.80	14157	837	772	1.20	4.40	20535	1332	1109	1.60	26712	-1594	
C	80	41	2.25	5.20	2.95	1.31	0.44	4.76	2440	-22	335	0.74	4.46	3707	-9	545	1.48	3.72	5724	118	1003	2.21	2.99	6611	378	1369	2.95	6950	-1311	
B	80	41	3	5.30	2.30	0.77	0.35	4.95	2854	109	270	0.58	4.72	4483	198	437	1.15	4.15	7838	474	814	1.73	3.57	10539	838	1145	2.30	12844	-1363	
	80	41	4	6.20	2.20	0.55	0.33	5.87	5407	203	298	0.55	5.65	8726	354	486	1.10	5.10	16213	783	924	1.65	4.55	22874	1288	1314	2.20	29122	-1738	
A	80	41	5	6.70	1.70	0.34	0.26	6.44	7330	263	253	0.43	6.27	11956	445	412	0.85	5.85	22928	924	786	1.28	5.42	33682	1460	1139	1.70	43952	-1679	
C	90	46	2.5	5.70	3.20	1.28	0.48	5.22	2800	-14	315	0.80	4.90	4232	2	509	1.60	4.10	6585	130	938	2.40	3.30	7684	385	1286	3.20	8157	-1246	
B	90	46	3.5	6.00	2.50	0.71	0.38	5.62	3721	122	282	0.63	5.37	5877	218	424	1.25	4.75	10416	509	792	1.88	4.12	14189	882	1116	2.50	17487	-1363	
A	90	46	5	7.00	2.00	0.40	0.30	6.70	6888	223	240	0.50	6.50	11267	382	394	1.00	6.00	21617	814	757	1.50	5.50	31354	1295	1088	2.00	40786	-1588	
	100	41	4	7.20	3.20	0.80	0.48	6.72	5535	131	269	0.80	6.40	8714	238	437	1.60	5.60	15219	577	818	2.40	4.80	20251	1017	1144	3.20	24547	-1465	
	100	41	5	7.75	2.75	0.55	0.41	7.34	7606	214	246	0.69	7.06	12386	376	405	1.38	6.37	23009	827	769	2.06	5.69	32328	1344	1088	2.75	41201	-1574	
C	100	51	2.7	6.20	3.50	1.30	0.53	5.67	3191	-17	306	0.88	5.32	4800	-3	492	1.75	4.45	7410	116	902	2.63	3.57	8613	359	1237	3.50	9091	-1191	
B	100	51	3.5	6.30	2.80	0.80	0.42	5.88	3572	91	246	0.70	5.60	5624	167	399	1.40	4.90	9823	411	749	2.10	4.20	13070	734	1049	2.80	15843	-1235	
	100	51	4	7.00	3.00	0.75	0.45	6.55	5482	124	292	0.75	6.25	8673	225	476	1.50	5.50	15341	540	894	2.25	4.75	20674	944	1255	3.00	25338	-1512	
	100	51	5	7.80	2.80	0.56	0.42	7.38	8637	204	303	0.70	7.10	13924	355	496	1.40	6.40	25810	789	942	2.10	5.70	36339	1301	1337	2.80	46189	-1764	
A	100	51	6	8.20	2.20	0.37	0.33	7.87	10401	249	250	0.55	7.65	17061	424	411	1.10	7.10	32937	897	790	1.65	6.55	48022	1418	1139	2.20	62711	-1663	
C	112	57	3	6.90	3.90	1.30	0.59	6.31	3893	-17	302	0.98	5.92	5856	-4	485	1.95	4.95	9038	112	889	2.93	3.97	10493	352	1220	3.90	11064	-1174	
B	112	57	4	7.20	3.20	0.80	0.48	6.72	4852	94	255	0.80	6.40	7639	173	415	1.60	5.60	13341	428	778	2.40	4.80	17752	765	1090	3.20	21518	-1284	
A	112	57	6	8.50	2.50	0.42	0.38	8.12	9797	215	237	0.63	7.87	15920	367	387	1.25	7.25	30215	777	737	1.88	6.62	43812	1243	1061	2.50	56737	-1505	
C	125	64	3.5	8.00	4.50	1.29	0.68	7.32	5671	-16	325	1.13	6.87	8542	0	524	2.25	5.75	13231	129	961	3.38	4.62	15422	390	1319	4.50	16335	-1273	
B	125	64	5	8.50	3.50	0.70	0.53	7.97	7765	130	268	0.88	7.62	12300	231	436	1.75	6.75	21924	537	816	2.63	5.87	29950	925	1151	3.50	37041	-1415	
C	140	72	3.8	8.70	4.90	1.29	0.74	7.96	6335	-16	308	1.23	7.47	9543	-2	497	2.45	6.25	14773	119	911	3.68	5.02	17201	364	1250	4.90	18199	-1203	
B	140	72	5	9.00	4.00	0.80	0.60	8.40	7631	94	258	1.00	8.00	12014	173	419	2.00	7.00	20982	428	787	3.00	6.00	27920	764	1101	4.00	33843	-1293	
C	160	82	4.3	9.90	5.60	1.30	0.84	9.06	8058	-18	304	1.40	8.50	12162	-6	491	2.80	7.10	18832	111	904	4.20	5.70	21843	350	1238	5.60	23022	-1189	
B	160	82	6	10.50	4.50	0.75	0.68	9.82	10947	110	260	1.13	9.37	17270	199	422	2.25	8.25	30431	474	790	3.38	7.12	41051	831	1110	4.50	50260	-1333	
C	180	92	4.8	11.00	6.20	1.29	0.93	10.07	9698	-15	295	1.55	9.45	14646	-2	476	3.10	7.90	22731	115	877	4.65	6.35	26442	350	1201	6.20	27966	-1159	
B	180	92	6	11.10	5.10	0.85	0.77	10.33	10631	77	246	1.28	9.82	16613	145	398	2.55	8.55	28552	368	742	3.83	7.27	37533	674	1036	5.10	44930	-1192	
C	200	102	5.5	12.50	7.00	1.27	1.05	11.45	13104	-12	306	1.75	10.75	19817	5	494	3.50	9.00	30882	131	910	5.25	7.25	36111	381	1247	7.00	38423	-1213	

STAINLESS STEEL DISC SPRINGS

STANDARD MATERIAL	
D	Austenitic Stainless Steel
STANDARD FINISH	
K	Plain

TO ORDER: Product / D_e x D_i x D_o x t / material code / finish code
 EXAMPLE: DSC 25 x 12.2 x 0.9 DK

DIN Series	Dimensions										Design Force, Deflection and Stresses Based on E = 190 kN/mm ² and μ = 0.3																							
	D _e	D _i	t	l _o	h _o	h _o /t	Preload, s = 0.15 h _o					s = 0.25 h _o					s = 0.5 h _o					s = 0.75 h _o					s = h _o							
							s	l _i	F	σ _{II}	σ _{III}	s	l _i	F	σ _{II}	σ _{III}	s	l _i	F	σ _{II}	σ _{III}	s	l _i	F	σ _{II}	σ _{III}	s	l _i	F	σ _{II}	σ _{III}	S	F	σ _{Om}
A	8	4.2	0.4	0.60	0.20	0.500	0.03	0.57	45	183	247	0.05	0.55	72	317	405	0.10	0.50	136	691	772	0.15	0.45	193	1124	1102	0.20	248	-1480					
B	10	5.2	0.4	0.70	0.30	0.750	0.05	0.65	56	129	304	0.08	0.62	86	223	476	0.15	0.55	143	497	841	0.23	0.47	196	898	1202	0.30	237	-1412					
A	10	5.2	0.5	0.75	0.25	0.500	0.04	0.71	74	196	261	0.06	0.69	108	303	386	0.13	0.62	218	723	792	0.19	0.56	304	1142	1103	0.25	385	-1471					
B	12.5	6.2	0.5	0.85	0.35	0.700	0.05	0.80	67	113	227	0.09	0.76	114	220	398	0.18	0.67	203	516	748	0.26	0.59	269	842	1019	0.35	335	-1281					
A	12.5	6.2	0.7	1.00	0.30	0.429	0.05	0.95	150	242	265	0.08	0.92	235	399	417	0.15	0.85	421	797	750	0.23	0.77	620	1308	1097	0.30	789	-1537					
B	14	7.2	0.5	0.90	0.40	0.800	0.06	0.84	70	87	238	0.10	0.80	111	160	387	0.20	0.70	194	395	725	0.30	0.60	258	705	1016	0.40	312	-1192					
A	14	7.2	0.8	1.10	0.30	0.375	0.05	1.05	177	235	241	0.08	1.02	279	385	379	0.15	0.95	505	762	686	0.23	0.87	750	1237	1007	0.30	959	-1431					
C	16	8.2	0.4	0.90	0.50	1.250	0.08	0.82	54	-5	242	0.13	0.77	80	11	381	0.25	0.65	121	108	678	0.38	0.52	143	306	939	0.50	153	-911					
B	16	8.2	0.6	1.05	0.45	0.750	0.07	0.98	104	105	247	0.11	0.94	156	177	379	0.23	0.82	285	450	743	0.34	0.71	380	773	1029	0.45	464	-1230					
A	16	8.2	0.9	1.25	0.35	0.389	0.05	1.20	195	198	209	0.09	1.16	344	367	370	0.18	1.07	660	760	711	0.26	0.99	926	1187	988	0.35	1217	-1435					
C	18	9.2	0.45	1.05	0.60	1.333	0.09	0.96	74	-20	251	0.15	0.90	111	-13	406	0.30	0.75	171	77	746	0.45	0.60	197	269	1020	0.60	206	-970					
B	18	9.2	0.7	1.20	0.50	0.714	0.08	1.12	144	119	254	0.13	1.07	223	209	403	0.25	0.95	384	469	730	0.38	0.82	528	826	1039	0.50	645	-1257					
A	18	9.2	1	1.40	0.40	0.400	0.06	1.34	254	206	222	0.10	1.30	416	353	363	0.20	1.20	798	751	698	0.30	1.10	1157	1195	1003	0.40	1505	-1437					
C	20	10.2	0.5	1.15	0.65	1.300	0.10	1.05	88	-14	247	0.16	0.99	129	-4	383	0.33	0.82	203	94	725	0.49	0.66	235	285	984	0.65	247	-944					
B	20	10.2	0.8	1.35	0.55	0.688	0.08	1.27	171	115	231	0.14	1.21	285	217	395	0.28	1.07	512	506	743	0.41	0.94	687	839	1026	0.55	857	-1279					
A	20	10.2	1.1	1.55	0.45	0.409	0.07	1.48	320	212	231	0.11	1.44	495	342	358	0.23	1.32	988	765	716	0.34	1.21	1412	1200	1015	0.45	1823	-1438					
C	22.5	11.2	0.6	1.40	0.80	1.333	0.12	1.28	147	-21	279	0.20	1.20	222	-13	450	0.40	1.00	341	91	827	0.60	0.80	392	310	1132	0.80	410	-1086					
B	22.5	11.2	0.8	1.45	0.65	0.813	0.10	1.35	184	88	239	0.16	1.29	279	155	374	0.33	1.12	498	401	721	0.49	0.96	655	708	999	0.65	789	-1177					
A	22.5	11.2	1.25	1.75	0.50	0.400	0.08	1.67	416	221	230	0.13	1.62	664	368	368	0.25	1.50	1227	751	679	0.38	1.37	1801	1214	988	0.50	2314	-1414					
C	25	12.2	0.7	1.60	0.90	1.286	0.14	1.46	209	-12	295	0.23	1.37	311	5	470	0.45	1.15	475	125	847	0.68	0.92	554	372	1167	0.90	586	-1142					
B	25	12.2	0.9	1.60	0.70	0.778	0.11	1.49	224	97	231	0.18	1.42	347	173	369	0.35	1.25	594	406	674	0.53	1.07	801	726	951	0.70	969	-1142					
A	25	12.2	1.5	2.05	0.55	0.367	0.08	1.97	567	223	214	0.14	1.91	976	400	369	0.28	1.77	1882	845	710	0.41	1.64	2684	1300	1000	0.55	3524	-1496					
C	28	14.2	0.8	1.80	1.00	1.250	0.15	1.65	265	-7	294	0.25	1.55	401	12	475	0.50	1.30	628	142	876	0.75	1.05	739	389	1203	1.00	792	-1182					
B	28	14.2	1	1.80	0.80	0.800	0.12	1.68	279	87	235	0.20	1.60	439	160	382	0.40	1.40	767	395	715	0.60	1.20	1021	706	1001	0.80	1238	-1182					
A	28	14.2	1.5	2.15	0.65	0.433	0.10	2.05	599	205	232	0.16	1.99	939	336	366	0.33	1.82	1842	746	722	0.49	1.66	2632	1182	1025	0.65	3394	-1441					
C	31.5	16.3	0.8	1.85	1.05	1.310	0.16	1.69	238	-17	260	0.26	1.59	352	-9	410	0.53	1.32	550	89	767	0.79	1.06	634	286	1044	1.05	666	-993					
B	31.5	16.3	1.25	2.15	0.90	0.720	0.14	2.01	475	120	263	0.23	1.92	743	212	422	0.45	1.70	1300	488	779	0.68	1.47	1774	855	1102	0.90	2176	-1330					
C	35.5	18.3	0.9	2.05	1.15	1.278	0.17	1.88	276	-11	240	0.29	1.76	425	2	397	0.58	1.47	660	103	730	0.86	1.19	767	293	992	1.15	815	-961					
B	35.5	18.3	1.25	2.25	1.00	0.800	0.15	2.10	428	84	232	0.25	2.00	674	155	377	0.50	1.75	1177	383	707	0.75	1.50	1567	685	990	1.00	1899	-1161					
C	40	20.4	1	2.30	1.30	1.300	0.20	2.10	363	-14	247	0.33	1.97	527	-3	395	0.65	1.65	808	90	716	0.98	1.32	939	285	984	1.30	989	-944					
B	40	20.4	1.5	2.65	1.15	0.767	0.17	2.48	639	98	241	0.29	2.36	1031	182	401	0.58	2.07	1814	442	753	0.86	1.79	2413	767	1046	1.15	2953	-1253					
C	45	22.4	1.25	2.85	1.60	1.280	0.24	2.61	635	-12	284	0.40	2.45	961	4	458	0.80	2.05	1495	123	843	1.20	1.65	1744	359	1156	1.60	1851	-1132					
C	50	25.4	1.25	2.85	1.60	1.280	0.24	2.61	521	-10	234	0.40	2.45	787	2	378	0.80	2.05	1029	98	697	1.20	1.65	1430	288	955	1.60	1518	-928					
C	56	28.5	1.5	3.45	1.95	1.300	0.29	3.16	885	-16	274	0.49	2.96	1350	-4	448	0.98	2.47	2089	105	824	1.46	1.99	2418	321	1122	1.95	2551	-1083					
C	63	31	1.8	4.15	2.35	1.306	0.35	3.80	1436	-18	304	0.59	3.56	2187	-3	496	1.18	2.97	3380	121	913	1.76	2.39	3908	369	1245	2.35	4116	-1213					
C	71	36	2	4.60	2.60	1.300	0.39	4.21	1748	-17	304	0.65	3.95	2639	-4	491	1.30	3.30	4088	115	904	1.95	2.65	4744	358	1238	2.60	5004	-1195					

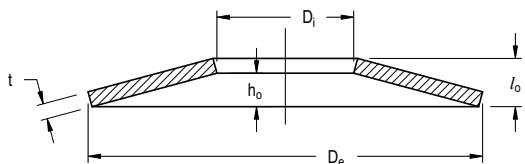

Axial preloading of bearings with **SPIROL** bearing Disc Springs extends the bearing life and eliminates excessive running noise.

One or more Disc Springs can be used. In most cases the outer race of the ball bearing is preloaded with the Disc Spring. In some cases it is desirable to preload the inner race. Accordingly, Disc Springs designed for the outer race of one bearing will also fit the inner race of another bearing.

The recommended preload is achieved when the disc is deflected to 75% of the free cone heights (h_o). The h_o/t ratio is designed so that the spring load remains nearly constant for a large deflection range. Tolerance build up and variations resulting from expansion can be accommodated without a significant change in preload.

Ball Bearing Size	Dimensions					$s = 0.75 h_o$			
	D_e	D_i	t	l_o	h_o	s, mm	F (N)		
623	EL3	9.8	6.2	0.2	0.4	0.2	0.15	23.2	
624	EL4	12.8	7.2	0.25	0.5	0.25	0.188	29.3	
625	634	EL5	15.8	8.2	0.25	0.55	0.3	0.225	23
626	635	EL6	18.8	9.2	0.3	0.65	0.35	0.263	31.3
607	EL7	18.8	10.2	0.35	0.7	0.35	0.263	50.7	
608	627	EL8	21.8	12.3	0.35	0.75	0.4	0.3	46.3
609	EL9	23.7	14.3	0.4	0.9	0.5	0.375	80.6	
600	629	25.7	14.3	0.4	0.9	0.5	0.375	63.5	
6001		27.7	17.3	0.4	1	0.6	0.45	80	
	6200	29.7	17.4	0.4	1.1	0.7	0.525	82.8	
6002	6201	31.7	20.4	0.4	1.1	0.7	0.525	81	
	6300	34.6	20.4	0.4	1.1	0.7	0.525	61.4	
6003	6202	34.6	22.4	0.5	1.2	0.7	0.525	118.4	
	6301	36.6	20.4	0.5	1.3	0.8	0.6	110.2	
	6203	39.6	25.5	0.5	1.3	0.8	0.6	109.9	
6004	6302	41.6	25.5	0.5	1.4	0.9	0.675	113.3	
6005	6204	46.5	30.5	0.6	1.5	0.9	0.675	153.5	
	6205	6304	51.5	35.5	0.6	1.5	0.9	0.675	135.5
6006		54.5	40.5	0.6	1.5	0.9	0.675	141.3	
6007	6206	6305	61.5	40.5	0.7	1.8	1.1	0.825	175.6
6008		67.5	50.5	0.7	1.7	1	0.75	161.3	
	6306	71.5	45.5	0.7	2.1	1.4	1.05	184.9	
	6207	71.5	50.5	0.7	2.1	1.4	1.05	218.3	
6009		74.5	55.5	0.8	1.9	1.1	0.825	211.3	
	6307	79.5	50.5	0.8	2.3	1.5	1.125	227.5	
6010	6208	79.5	55.5	0.8	2.3	1.5	1.125	263.4	
	6209	84.5	60.5	0.9	2.5	1.6	1.2	358.7	
	6308	89.5	60.5	0.9	2.5	1.6	1.2	287.8	
6011	6210	89.5	65.5	0.9	2.5	1.6	1.2	335.3	
6012		94.5	75.5	1	2.2	1.2	0.9	324.7	
	6309	99	65.5	1	2.6	1.6	1.2	292.3	
6013	6211	99	70.5	1	2.6	1.6	1.2	332.3	
	6310	109	70.5	1.25	2.7	1.45	1.088	357.1	
6014	6212	109	75.5	1.25	2.7	1.45	1.088	397.9	
6015		114	90.5	1.25	2.45	1.2	0.9	398.2	
	6311	119	75.5	1.25	2.8	1.55	1.163	319.9	
	6213	119	85.5	1.25	2.8	1.55	1.163	392.6	
6016	6214	124	90.5	1.25	3	1.75	1.313	444.8	

STANDARD MATERIALS	
B	"t" less than 1.25mm High Carbon Steel
W	"t" 1.25mm and thicker Alloy Steel
Austempered to HRC 42 - 52 / HV 412 - 544	
STANDARD FINISH	
R	Phosphate coated, oiled

TO ORDER: Product / D_e x D_i x t / material code / finish code
 EXAMPLE: BRG 41.6 x 25.5 x 0.5 BR

Note: All Ball Bearing Disc Springs are made to order.

Predictable preloading of bearings results in quiet running and long life. Disc Springs may also be used to preload seals, packings, clutches and other machine elements.

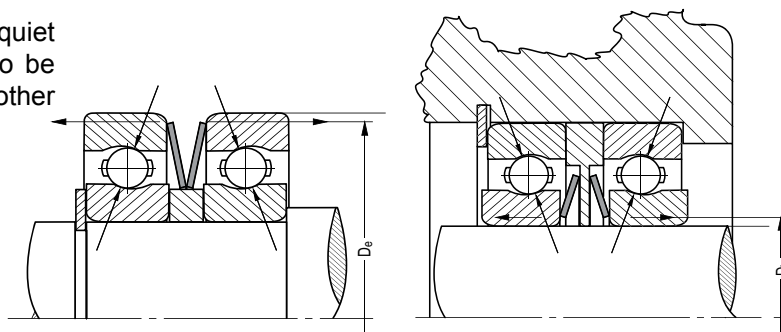

Mechanical Braking System

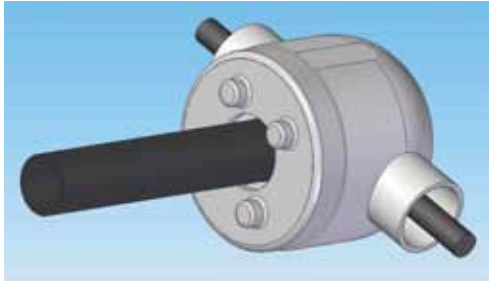

Application:

Braking systems for off-highway equipment are commonly designed to be hydraulically actuated. In most cases, braking occurs when pressurized fluid compresses stationary friction discs against plates that rotate with the drive shaft. The amount of friction between each set of plates controls the deceleration of the vehicle. Without an additional fail safe system, this design alone has limited reliability. If a hydraulic seal is compromised, or the hydraulic cylinder loses pressure for any reason, the brakes fail.

Solution:

The mechanical back-up design uses **SPIROL®** Disc Springs. Under normal circumstances, the hydraulic system holds a constant pressure on Disc Springs stacked in series. If pressure fails to be maintained, the stack of Disc Springs decompresses to actuate the braking mechanism. A compression spring or wave spring is not capable of providing the force required (in the space available) to actuate the brakes. The reliability of this safety system is dependent on the consistent performance of Disc Springs. In this critical application, the Disc Spring's performance and level of predictability improves product quality and ensures overall safety.

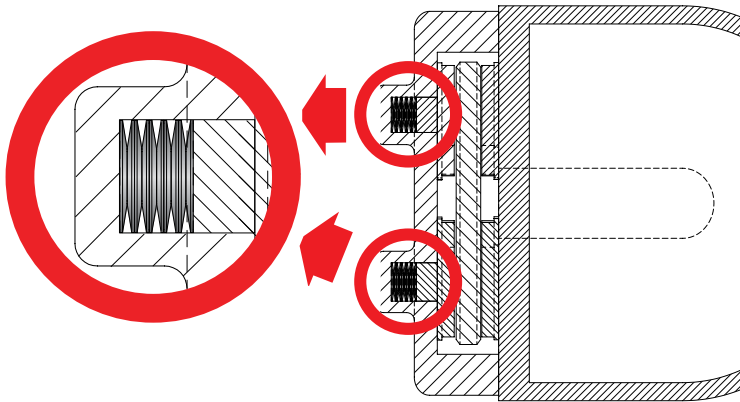

SPIROL® Disc Springs have a consistently high capacity to store potential mechanical energy. The conical design of **SPIROL®** Disc Springs makes their spring characteristics and performance more predictable than traditional compression springs. Disc Springs are also capable of providing more force in less space than a compression spring or wave spring. They are commonly stacked in multiples to achieve application specific spring rates: a stack in series provides less force over more travel; a stack in parallel provides more force over less travel. The precise tolerances of each individual Disc Spring provides unparalleled performance predictability when they are stacked (either in series or in parallel).

SPIROL® Disc Springs also allow fatigue endurance to be predicted. Stress analysis enables the minimum cycle life of Disc Springs (singularly or stacked) to be calculated as a part of the application's design.

Pick-Off Unit for CNC Machines

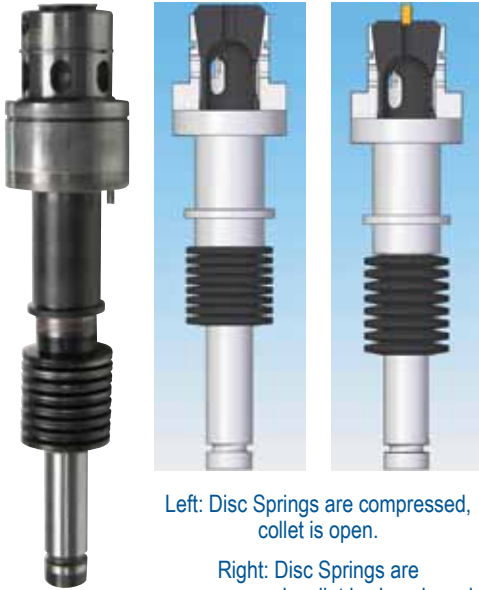

Left: Disc Springs are compressed, collet is open.
 Right: Disc Springs are uncompressed, collet is closed, work piece is clinched.

Application:

Pick-off spindles in CNC screw machines are designed to hold a part as it is cut to length and then finished. The spindle uses a collet to release the part when it is complete and then clinch a new part.

When the machine is setup, the clamping force required to hold each part in the collet must be precisely calibrated to prevent the finished product from slipping (if the force is too low) or being crushed (if the force is too high). This calibration is dependent on the geometry and material of the final product. After calibration, the quality of the finished product relies on a consistent clamping force for thousands of cycles at a time.

Solution:

This high degree of reliability is provided by **SPIROL®** Disc Springs. When the collet is opened, 16 **SPIROL®** Disc Springs stacked in series are compressed by a hydraulic cylinder. Each time the force from the cylinder is released, **SPIROL®** Disc Springs provide a consistent force to close the collet on the part.

Pipe Supports for Industrial Pipe Systems

Application:

As mandated by the ASME code for pressure piping, proper design and installation is critical for the performance and safety of piping systems. Industrial pipe systems are primarily supported by rod hangers, base line or base elbow supports. While these static supports are used to carry weight, dynamic supports are necessary to control loads on the pipe system.

Solution:

For example, in heat exchanger applications, **SPIROL®** Disc Springs are used to accept thermal dynamics. As the temperature of the fluid within the pipe changes, the pipe will expand (when hot) and contract (when cold) accordingly. **SPIROL®** Disc Springs support the system by maintaining a constant pressure at any temperature. This consistency is transmitted to the pipe joint and is essential for maintaining a proper seal. A well sealed gasket prevents fluids from escaping and reduces costly maintenance.

SPIROL® Disc Springs offer an advantage to coil springs by providing an equivalent displacement in a fraction of the space. In many instances, such as under a heat exchangers bottom flange, this space savings is required. **SPIROL®** Disc Springs are the solution to providing a robust, maintenance free support system for industrial pipe systems.

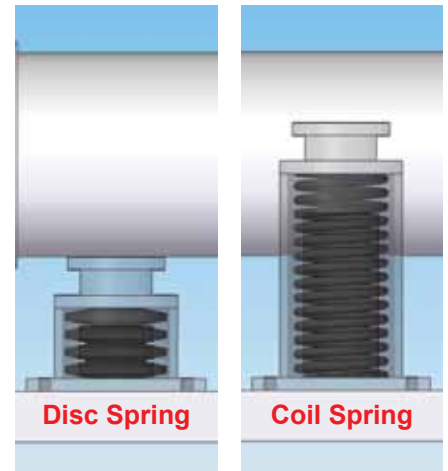
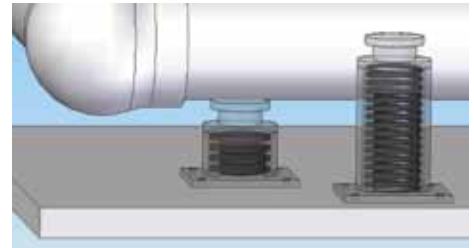

A coil spring cannot provide the proper support given the limited space in this example. Only a Disc Spring stack is able to package the required load and travel in the restricted space.

SPIROL®

Innovative fastening solutions.
Lower assembly costs.



Please refer to www.SPIROL.com for the most current specifications and standard offering.
Printed materials may be out of date.

SPIROL Application Engineers will review your application needs and work with your design team to recommend the best solution. One way to start the process is to visit our **Optimal Application Engineering** portal at www.SPIROL.com.

ISO/TS 16949 Certified
ISO 9001 Certified

e-mail: info@spirol.com

SPIROL.com

© 2014 SPIROL International Corporation 11/14

Technical Centers

Americas

SPIROL International Corporation
30 Rock Avenue
Danielson, Connecticut 06239 U.S.A.
Tel. +1 860 774 8571
Fax. +1 860 774 2048

SPIROL Shim Division
321 Remington Road
Stow, Ohio 44224 U.S.A.
Tel. +1 330 920 3655
Fax. +1 330 920 3659

SPIROL West
1950 Compton Avenue, Unit 111
Corona, California 92881 U.S.A.
Tel. +1 951 273 5900
Fax. +1 951 273 5907

SPIROL Canada
3103 St. Etienne Boulevard
Windsor, Ontario N8W 5B1 Canada
Tel. +1 519 974 3334
Fax. +1 519 974 6550

SPIROL Mexico
Carretera a Laredo KM 16.5 Interior E
Col. Moisés Saenz
Apodaca, N.L. 66613 Mexico
Tel. +52 81 8385 4390
Fax. +52 81 8385 4391

SPIROL Brazil
Rua Mafalda Barnabé Soliane, 134
Comercial Vitória Martini, Distrito Industrial
CEP 13347-610, Indaiatuba, SP, Brazil
Tel. +55 19 3936 2701
Fax. +55 19 3936 7121

Europe

SPIROL France
Cité de l'Automobile ZAC Croix Blandin
18 Rue Léna Bernstein
51100 Reims, France
Tel. +33 3 26 36 31 42
Fax. +33 3 26 09 19 76

SPIROL United Kingdom
17 Princewood Road
Corby, Northants
NN17 4ET United Kingdom
Tel. +44 1536 444800
Fax. +44 1536 203415

SPIROL Germany
Prannerstrasse 15
80333 Munich, Germany
Tel. +49 89 4 111 905 71
Fax. +49 89 4 111 905 72

SPIROL Spain
08940 Cornellà de Llobregat
Barcelona, Spain
Tel. +34 93 193 05 32
Fax. +34 93 193 25 43

SPIROL Czech Republic
Sokola Tůmy 743/16
Ostrava-Mariánské Hory 70900
Czech Republic
Tel/Fax. +420 417 537 979

Asia Pacific

SPIROL Asia Headquarters
1st Floor, Building 22, Plot D9, District D
No. 122 HeDan Road
Wai Gao Qiao Free Trade Zone
Shanghai, China 200131
Tel. +86 21 5046 1451
Fax. +86 21 5046 1540

SPIROL Korea
160-5 Seokchon-Dong
Songpa-gu, Seoul, 138-844, Korea
Tel. +86 (0) 21 5046-1451
Fax. +86 (0) 21 5046-1540